

OSNOVE LIFTA

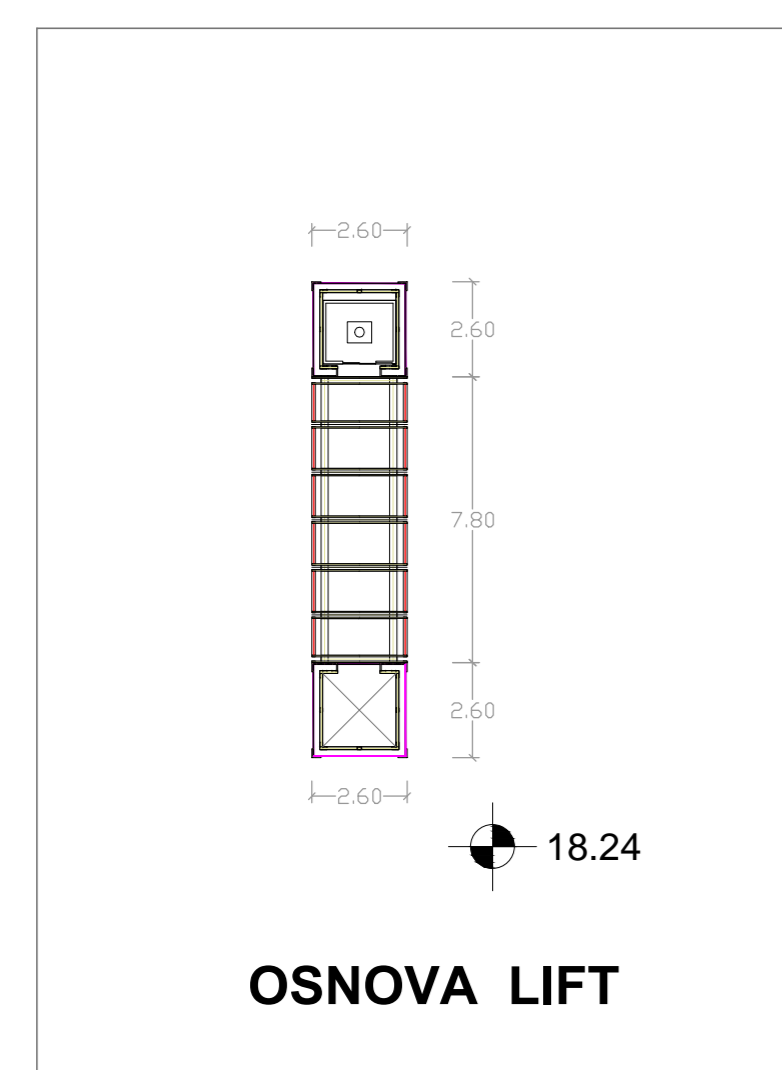

OSNOVA LIFT

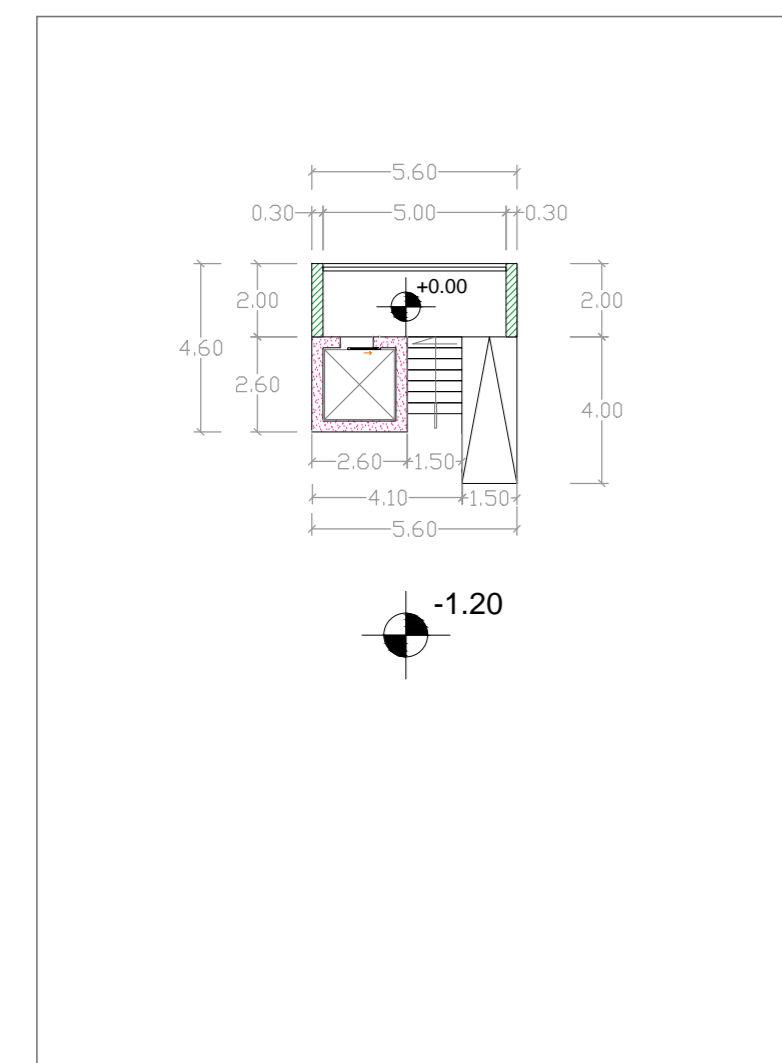
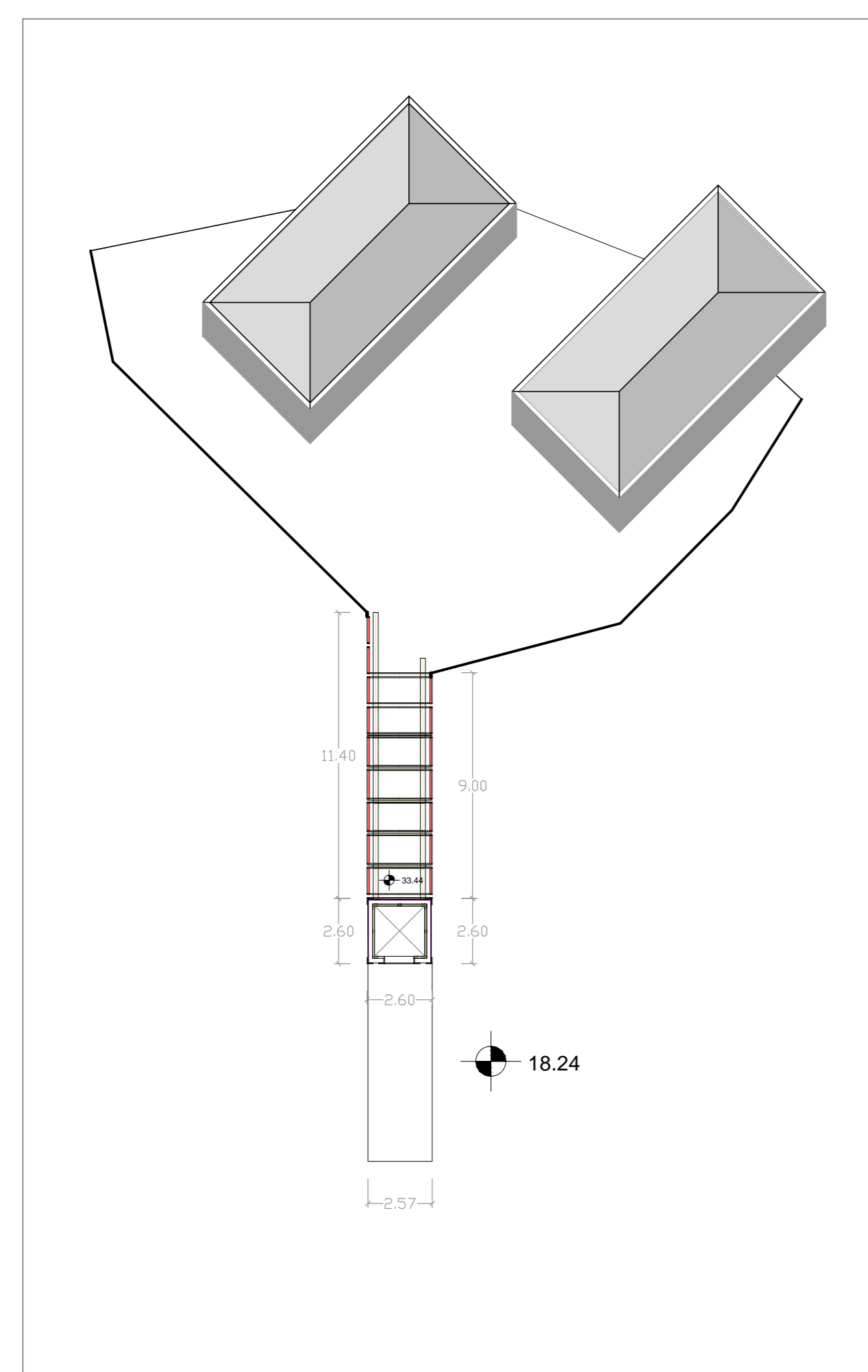
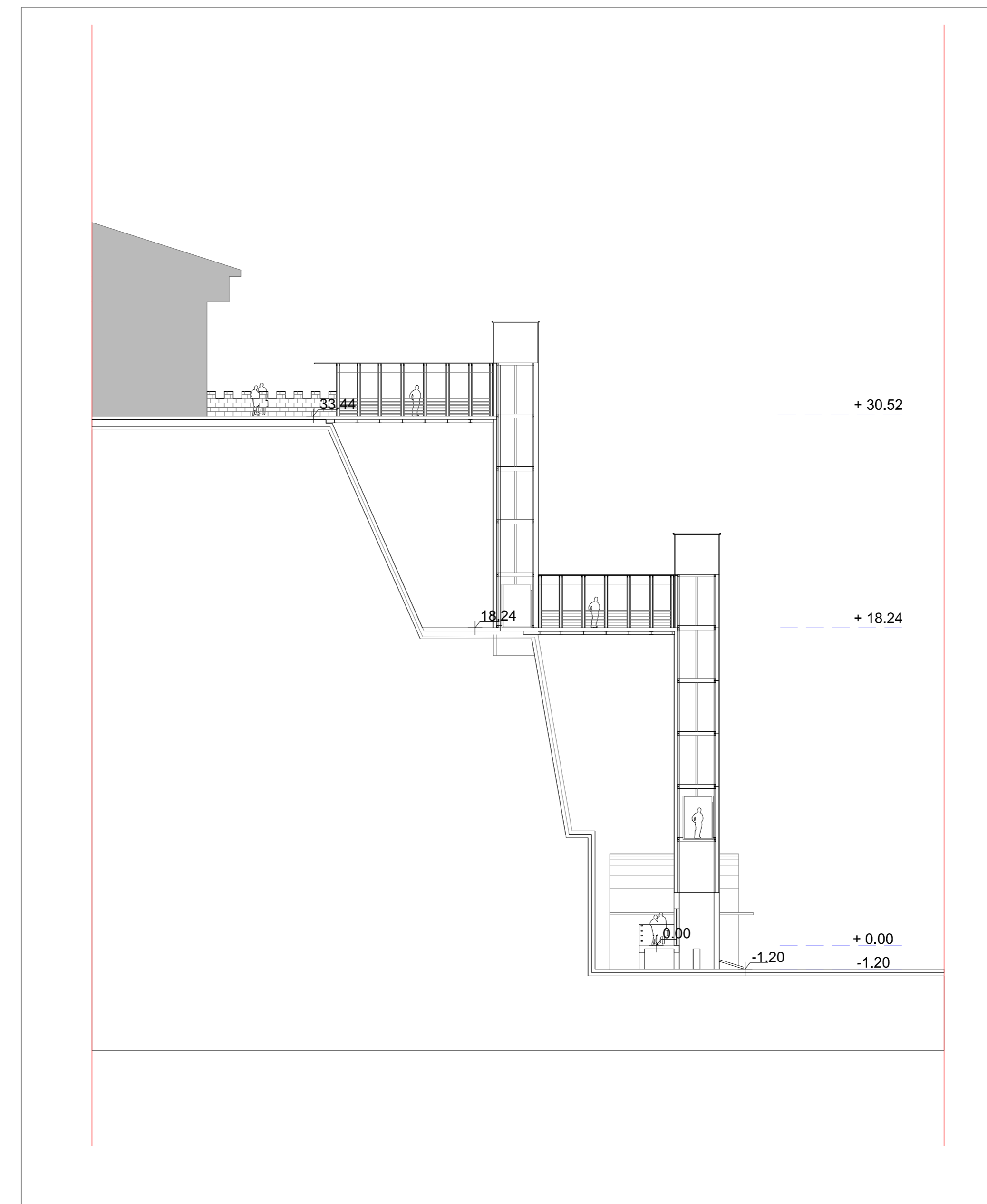
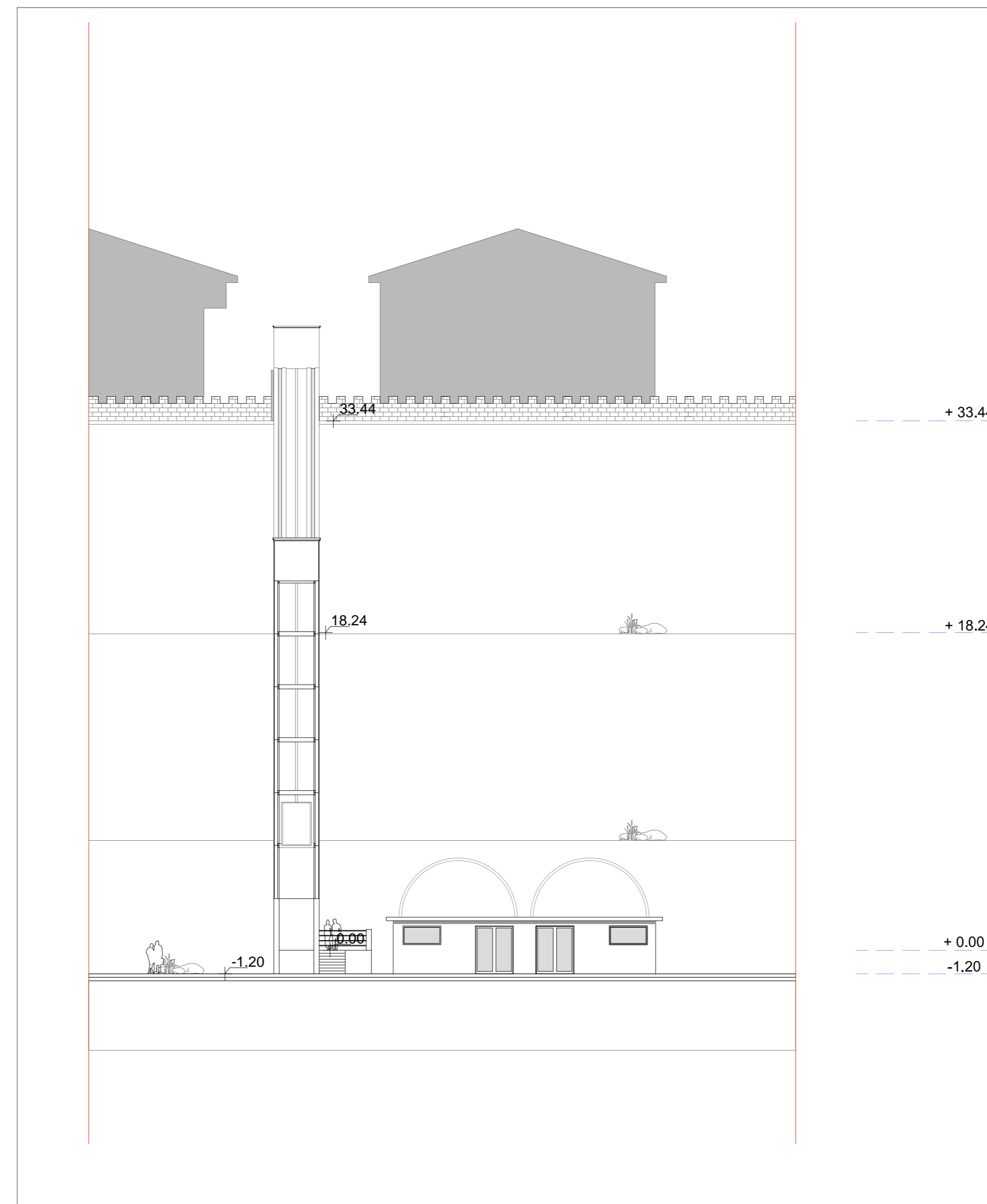

Perspektiva

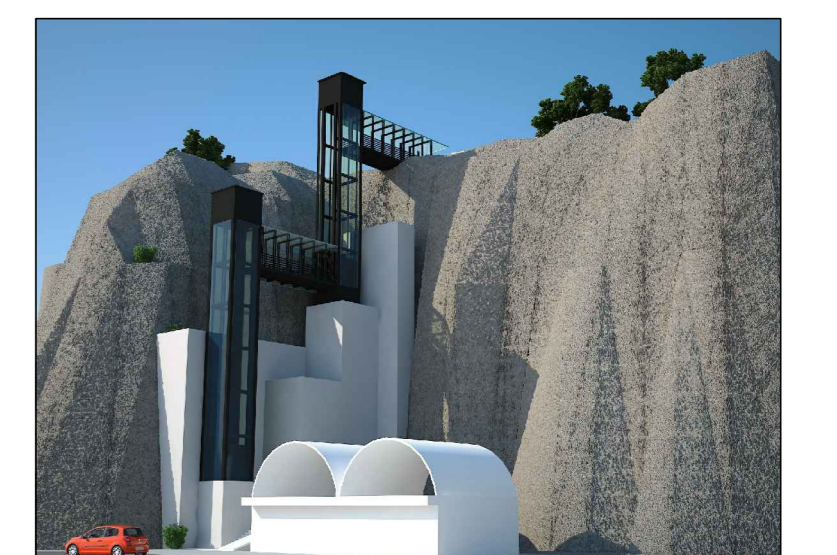

Investitor:	SKUPŠTINA OPŠTINE ULCINJ	Teh. broj:	
Datum:	April 2015.	Šifra objekta:	
Naziv objekta i mjesto gradnje:	Urbanistički Projekat "PRISTAN" – Ulcinj – LOT 3		
Vrsta projekta:	UP	Šifra vrste:	
Dió projekta:	URBANISTIČKI PROJEKAT	Šifra dijela:	
Crtač:		Razmjera:	1 : 200
	PLAN INTERVENCIJA	LIST br.:	03